

# **Circuit Diagram**

**Finisher, Sorter, Delivery Tray  
Finisher-Q1**

**Canon**



## IMPORTANT

This documentation is published by Canon Inc., Japan, to serve as a source of reference for work in the field.

Specifications and other information contained herein may vary slightly from actual machine values or those found in advertising and other printed matter.

Any questions regarding the information contained herein should be directed to the Copier Service Department of the Sales Company.

This documentation is intended for all sales areas, and may contain information not applicable to certain areas.

Reproduction without permission not allowed.

Use of this manual should be strictly supervised to avoid disclosure of confidential information.

***COPYRIGHT 2001 CANON INC.***

*Printed in Japan*

### Caution

Use of this manual should be strictly supervised to avoid disclosure of confidential information.



## Contents

1 Finisher Controller PCB.....	1
Finisher Controller PCB (A501) .....	1
Finisher Controller PCB (A502) .....	2
Finisher Controller PCB (A503) .....	3
Finisher Controller PCB (A504) .....	4
Finisher Controller PCB (A505) .....	5
Finisher Controller PCB (A506) .....	6
Finisher Controller PCB (A507) .....	7
Finisher Controller PCB (A508) .....	8
Finisher Controller PCB (A509) .....	9
Finisher Controller PCB (A510) .....	10
Finisher Controller PCB (A511) .....	11
Finisher Controller PCB (A512) .....	12
Finisher Controller PCB (A513) .....	13
Finisher Controller PCB (A514) .....	14
2 Stapler PCB 1 .....	15
Stapler PCB1 .....	15
3 Stapler PCB 2 .....	17
Stapler PCB2 .....	17
4 Tray2 Shift Area Sensor PCB .....	19
Tray1/Tray2 Shift Area Sensor PCB.....	19
5 Tray1/Tray2 Driver PCB.....	21
Tray1/Tray2 Driver PCB.....	21





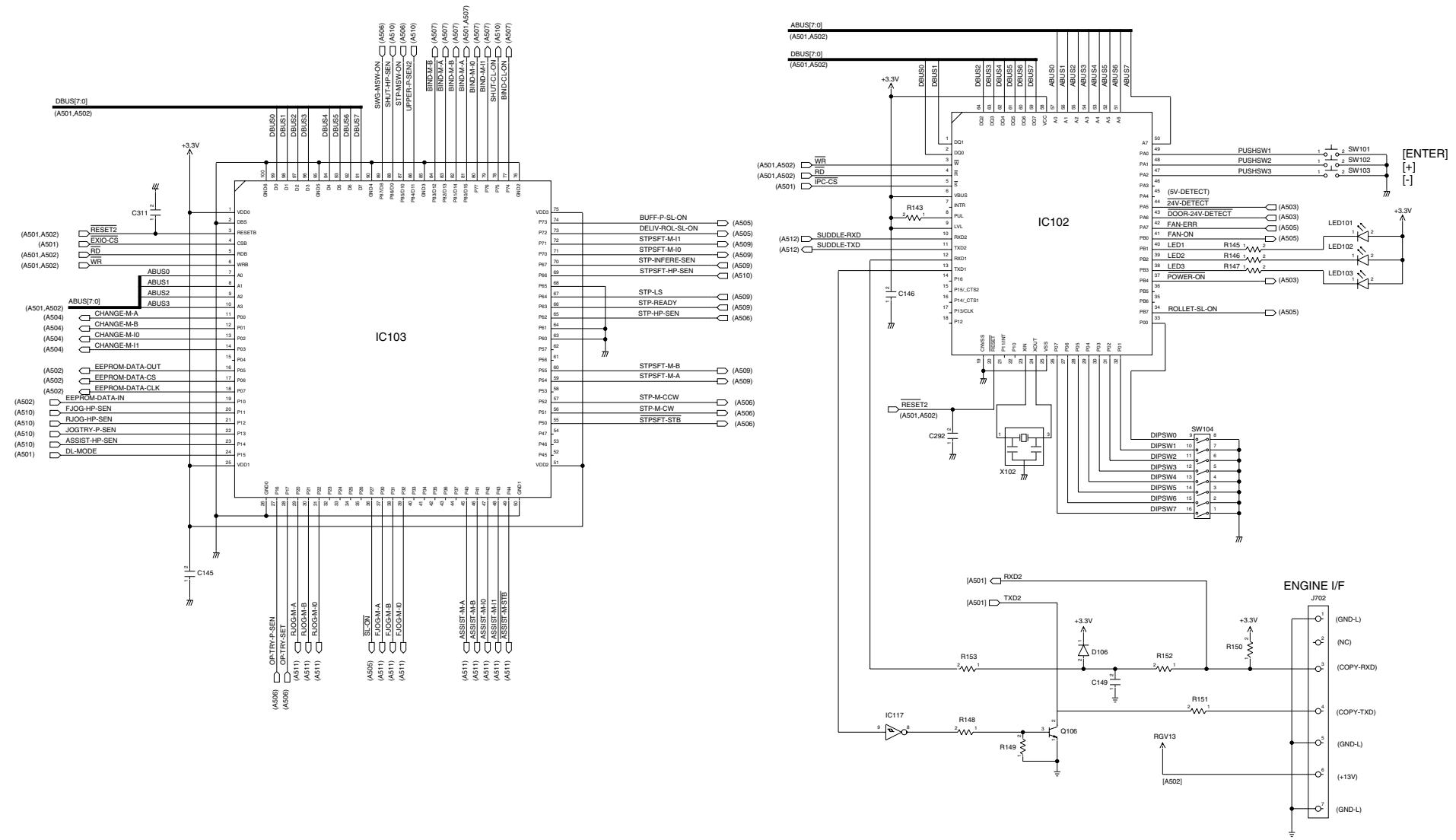

F-1-2



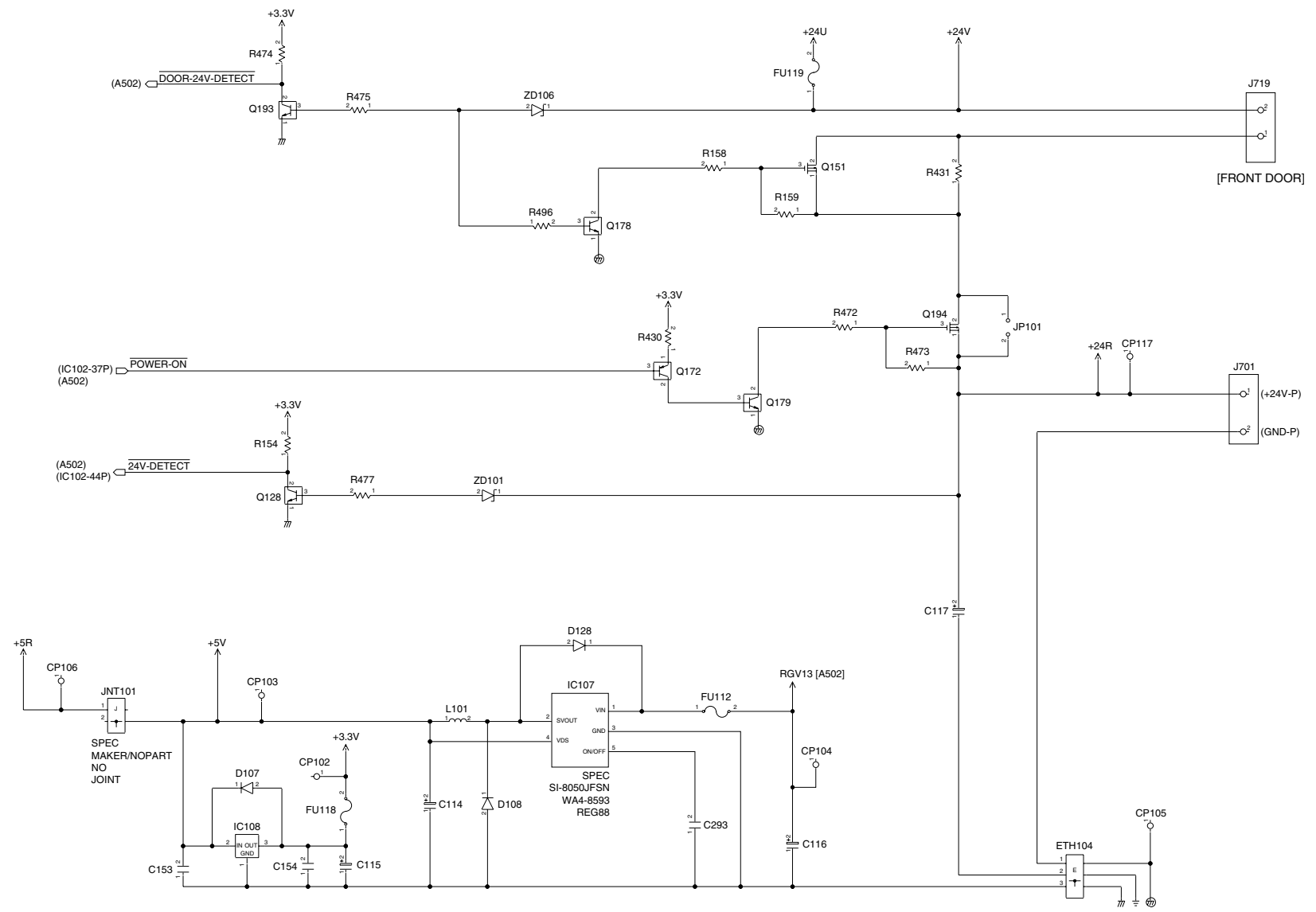

F-1-3

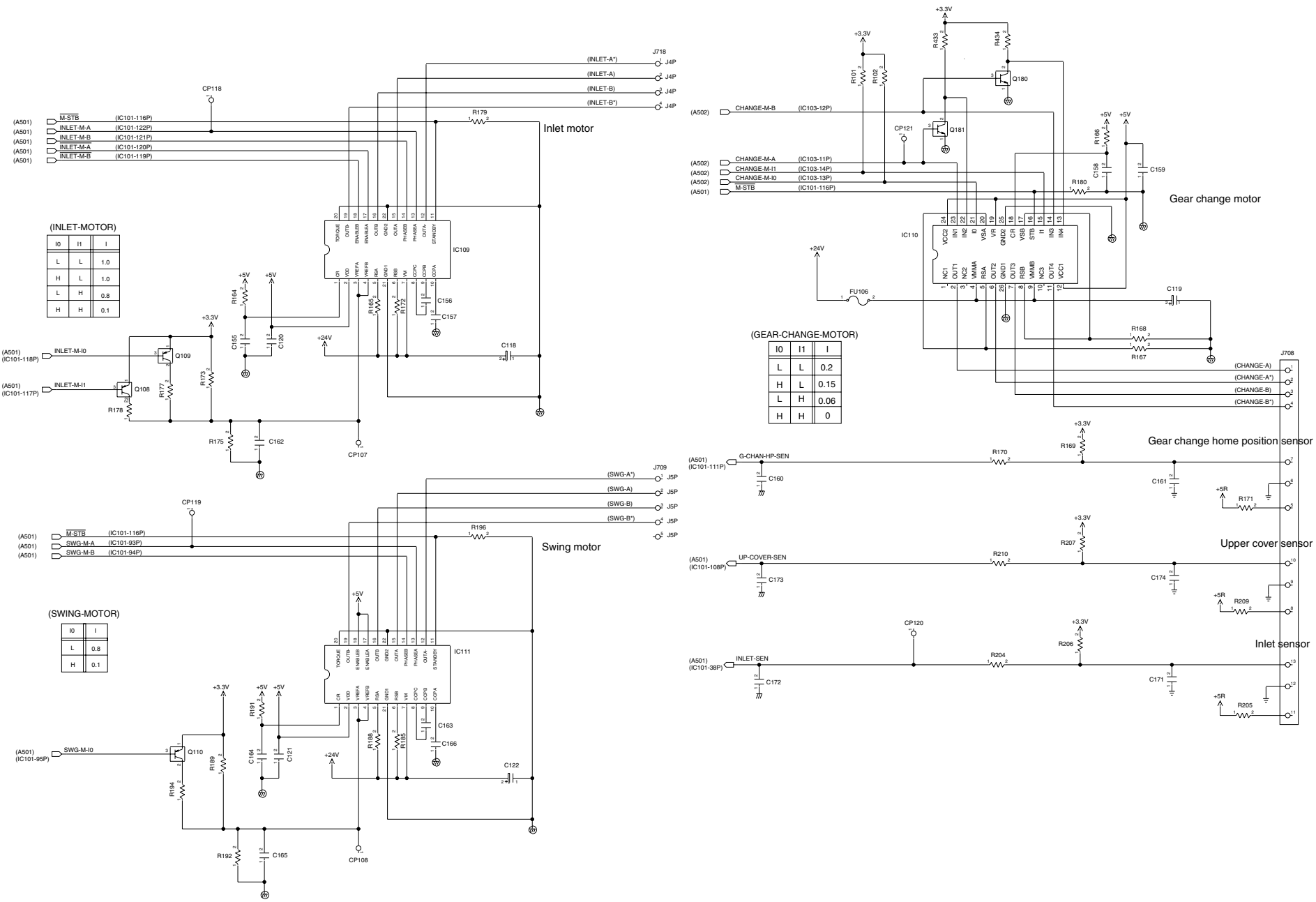

F-1-4

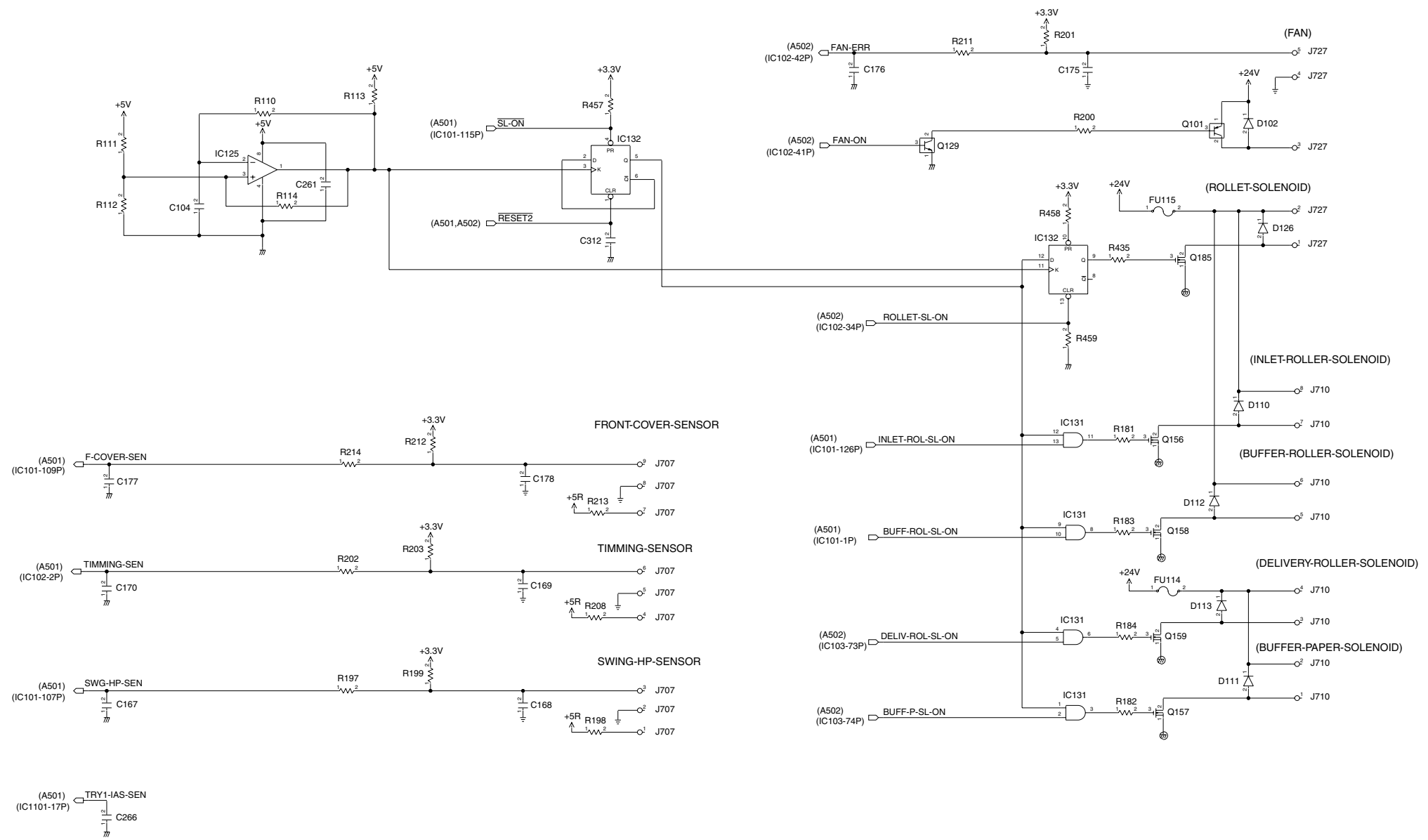

F-1-5

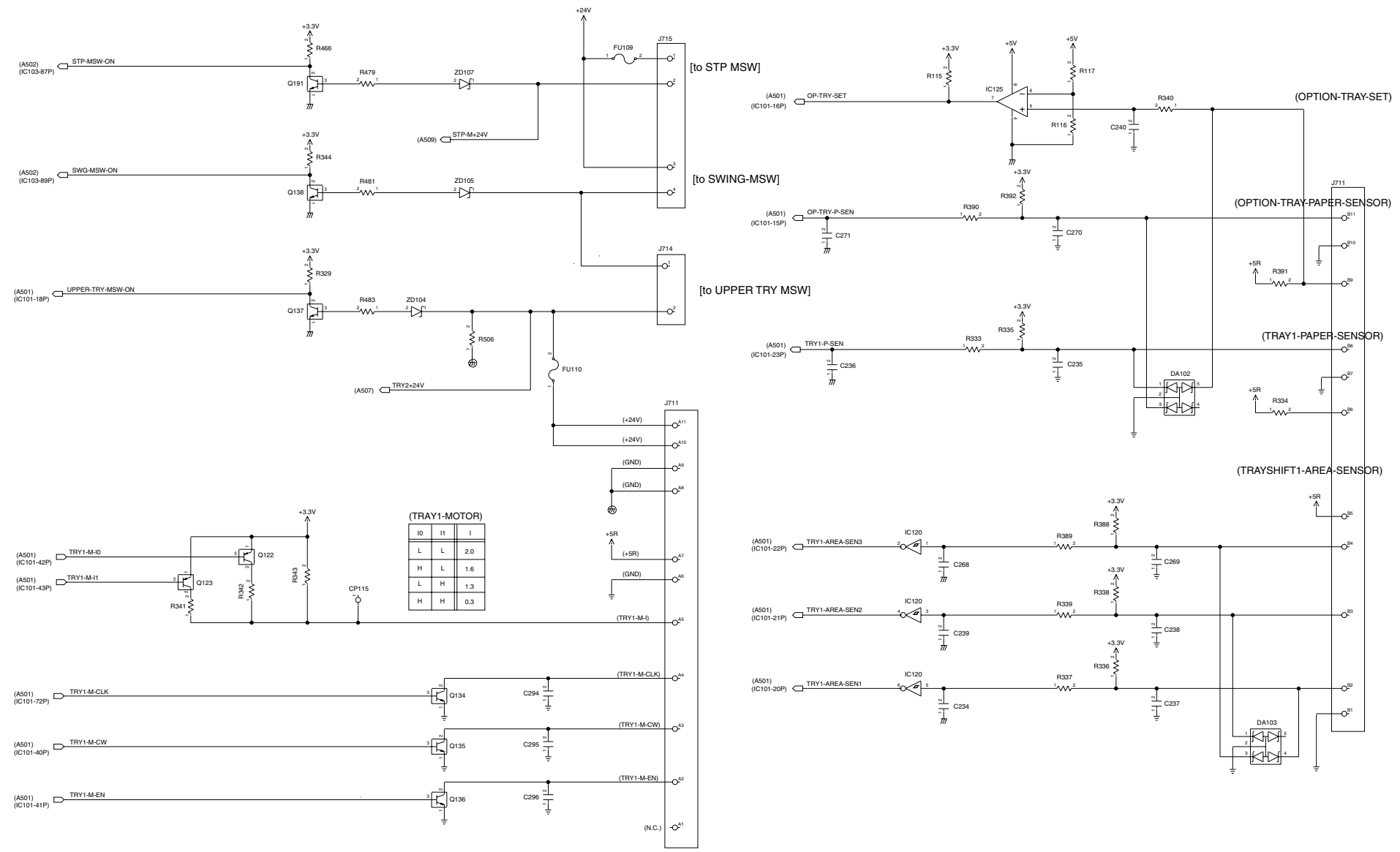

F-1-6

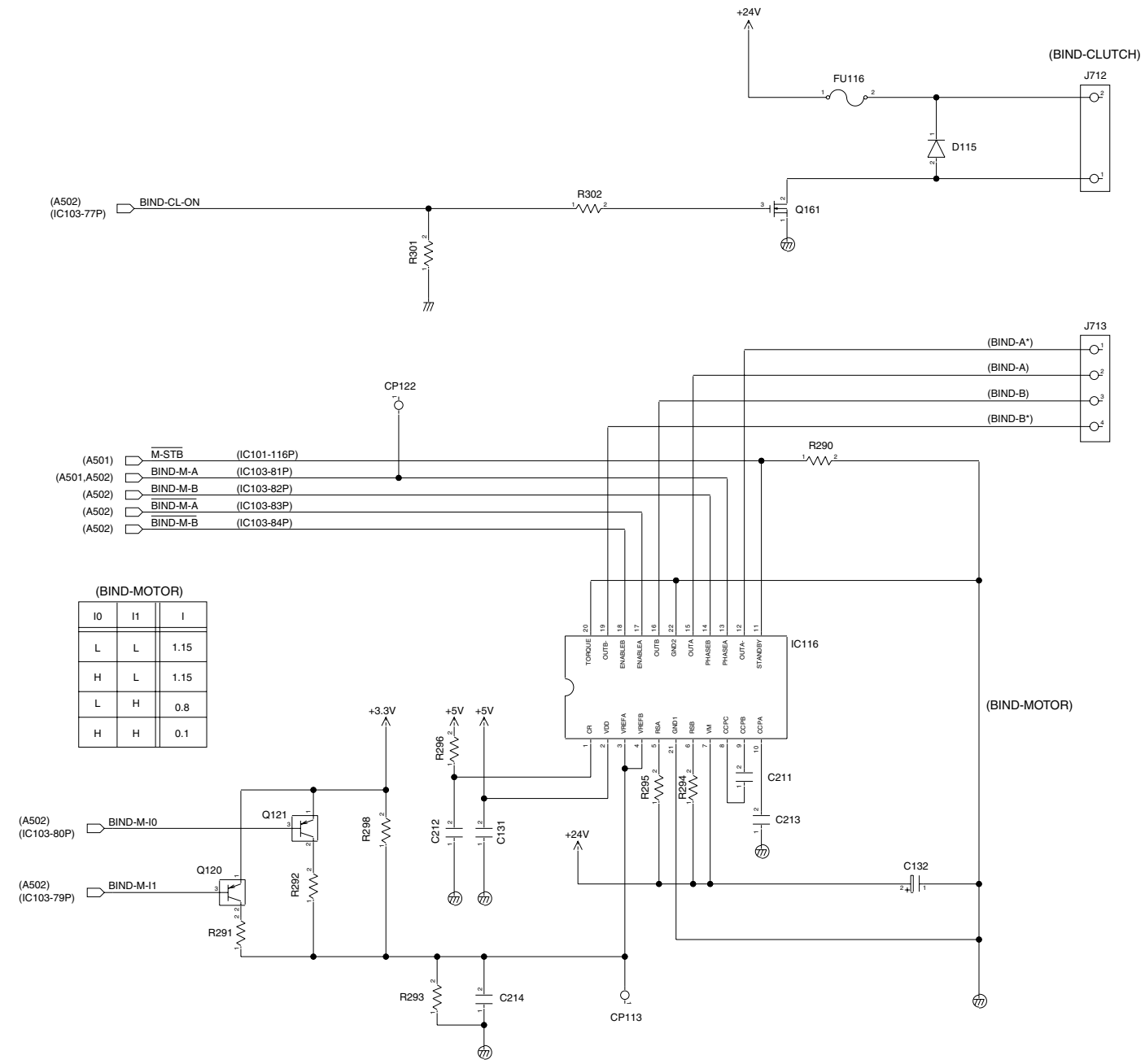

F-1-7

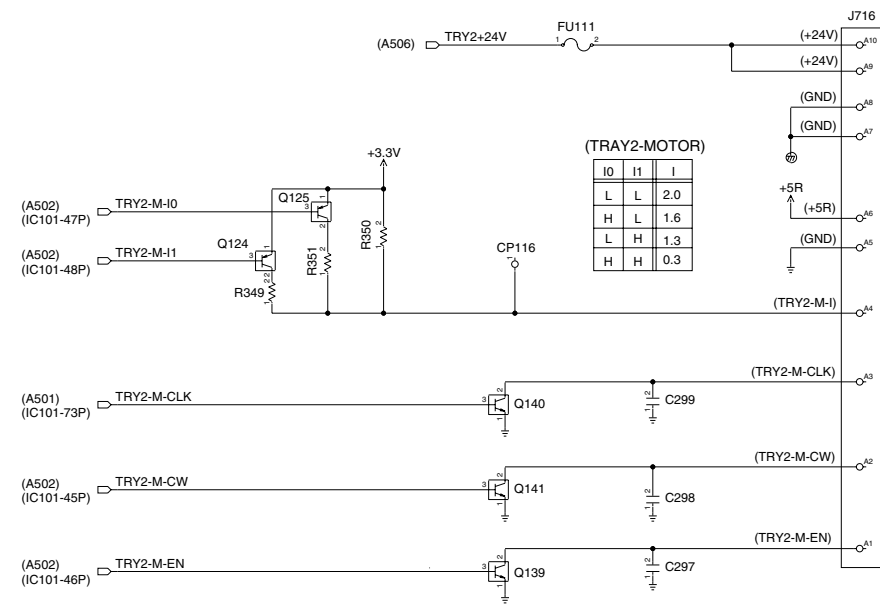

F-1-8

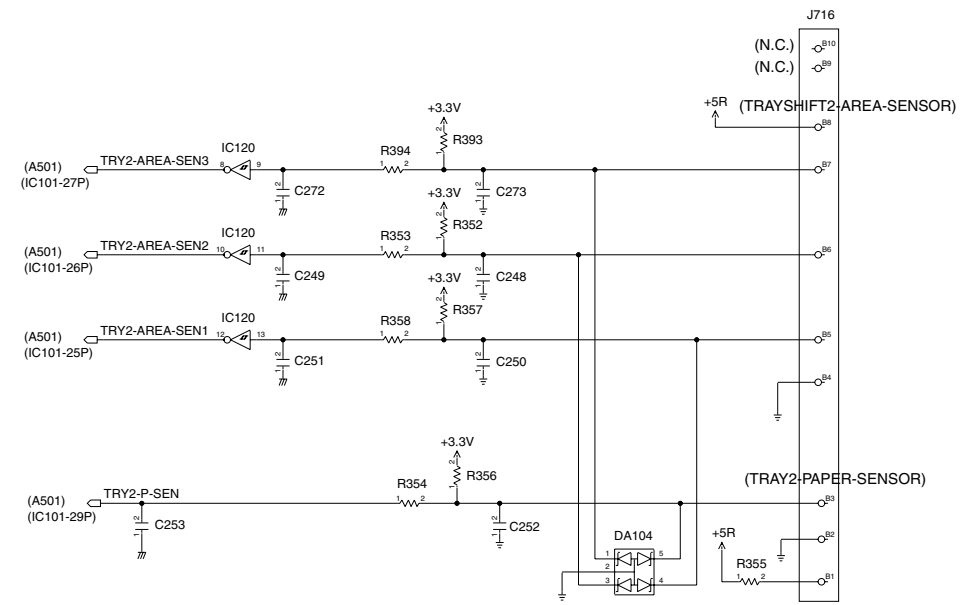

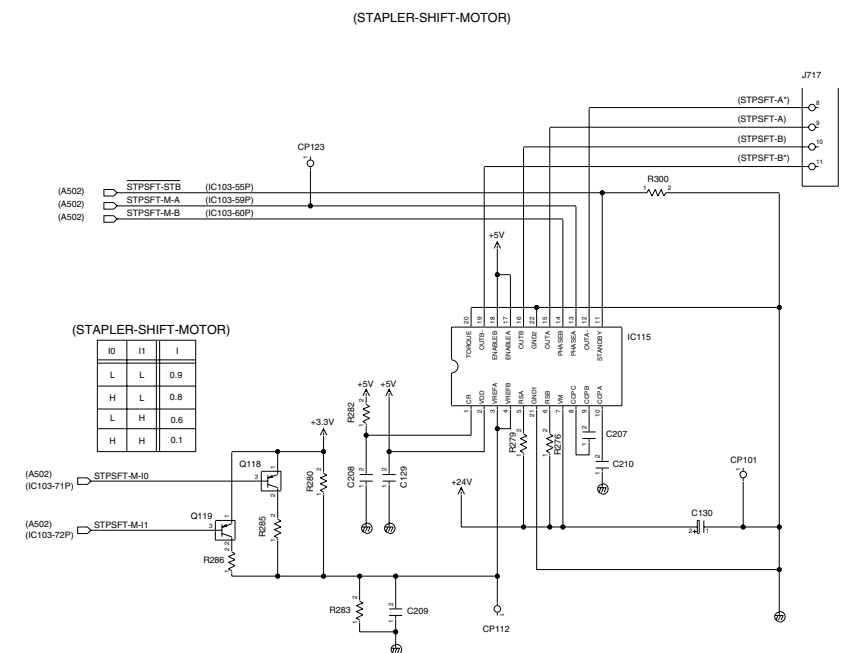
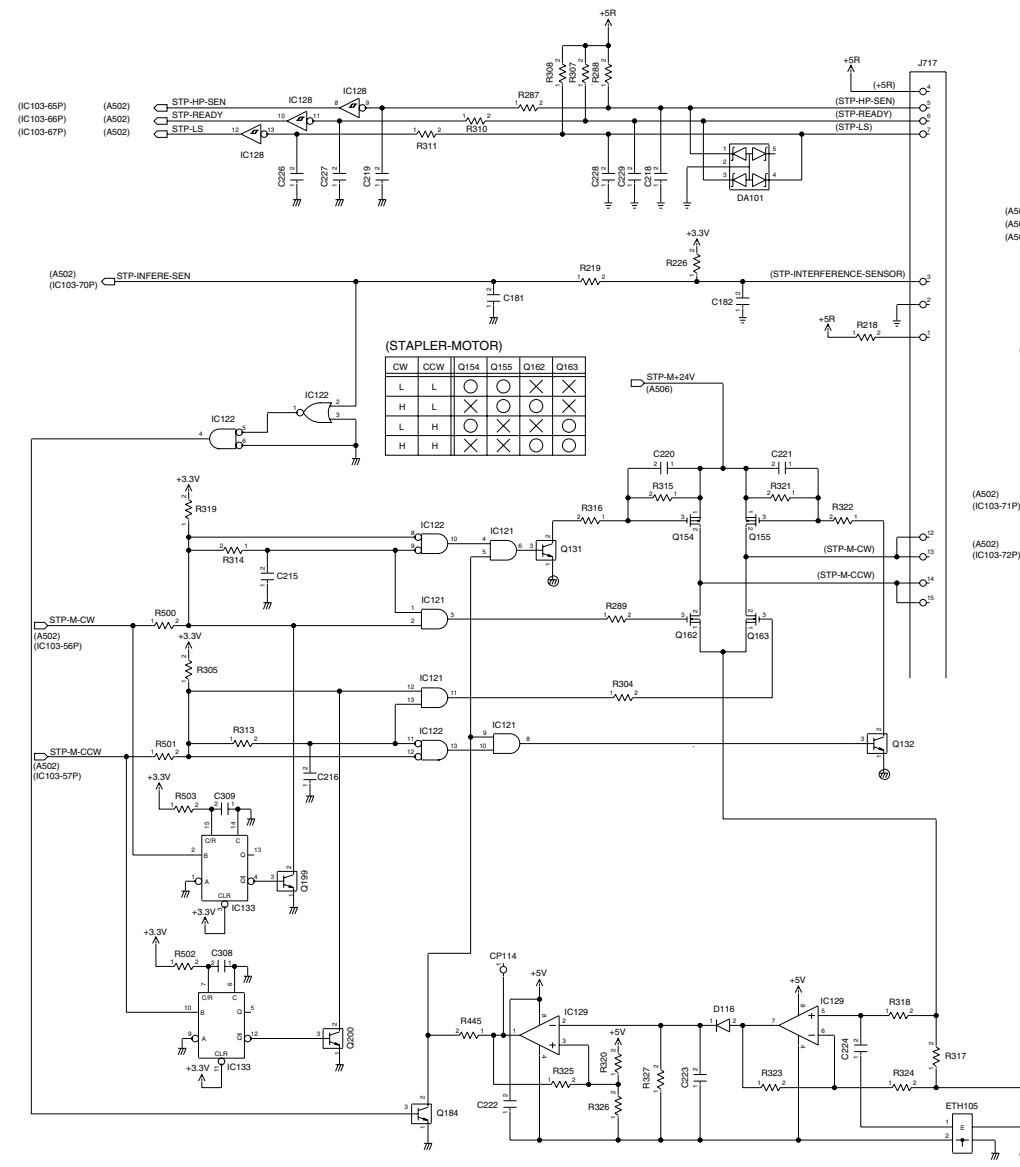

F-1-9

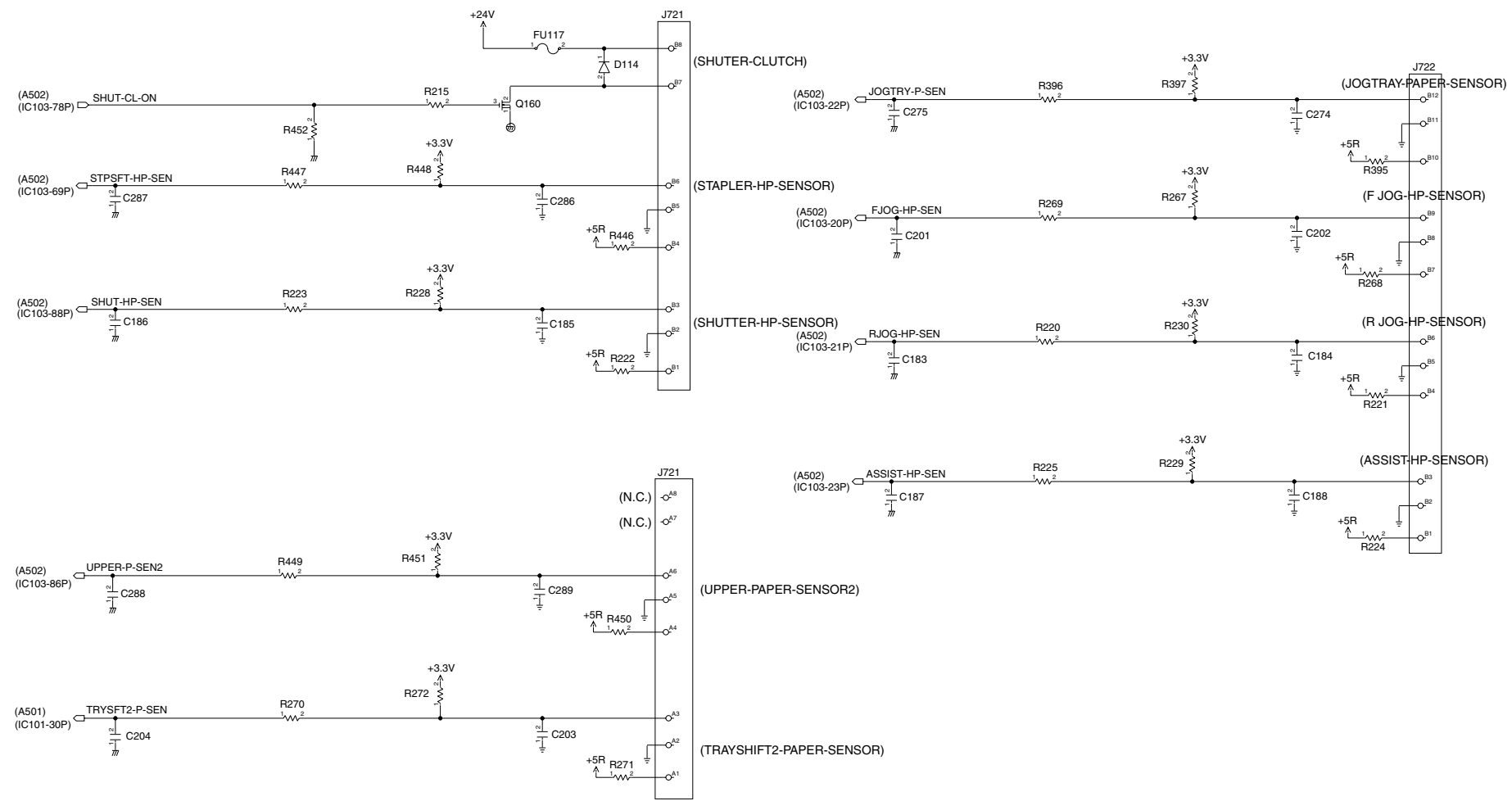

F-1-10



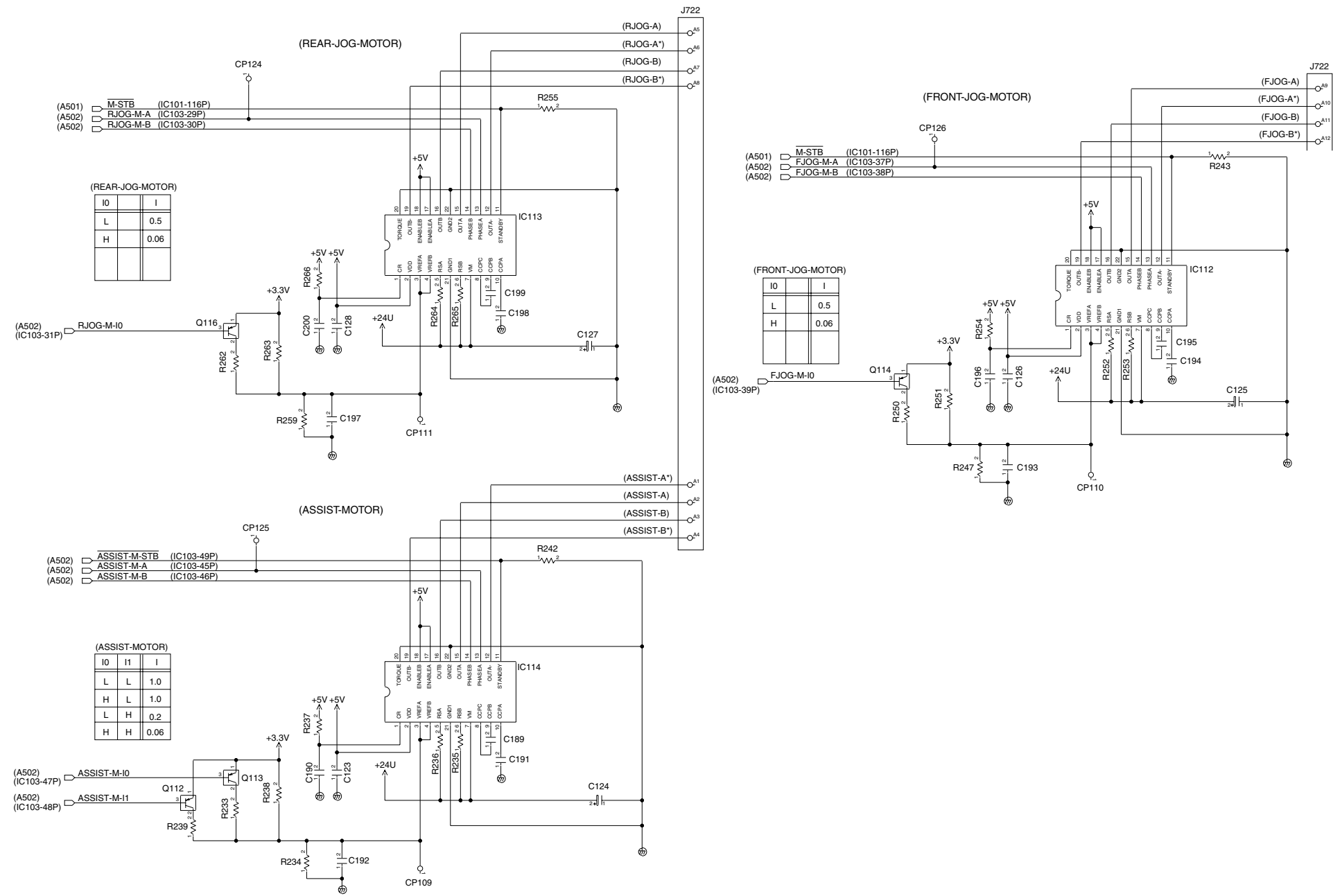

F-1-11

SADDLE I/F

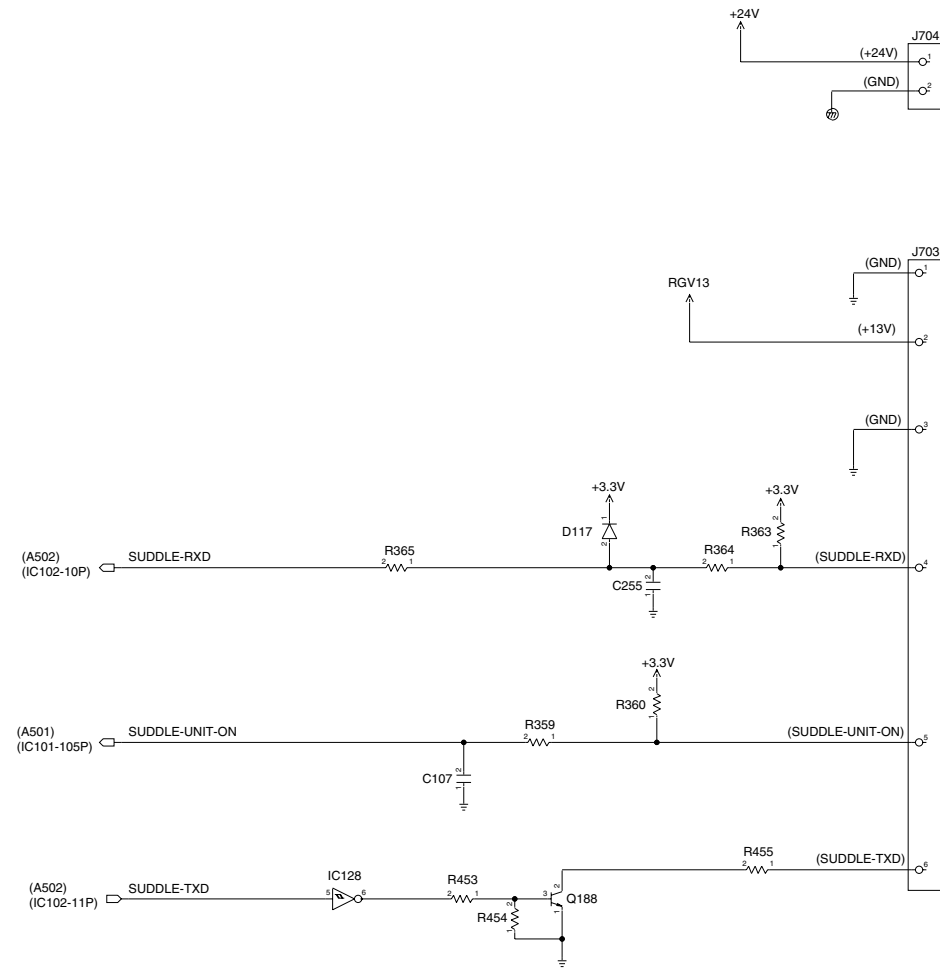

EXAM I/F

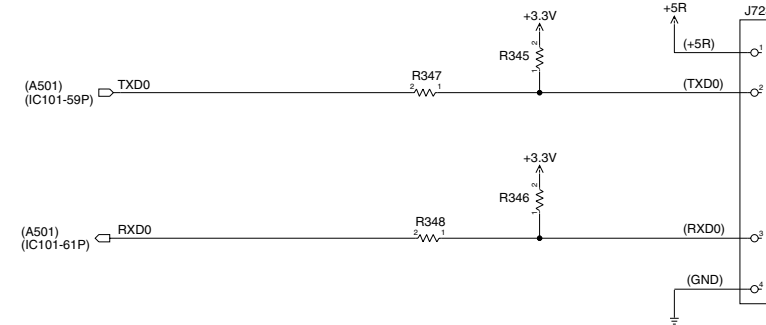

F-1-12

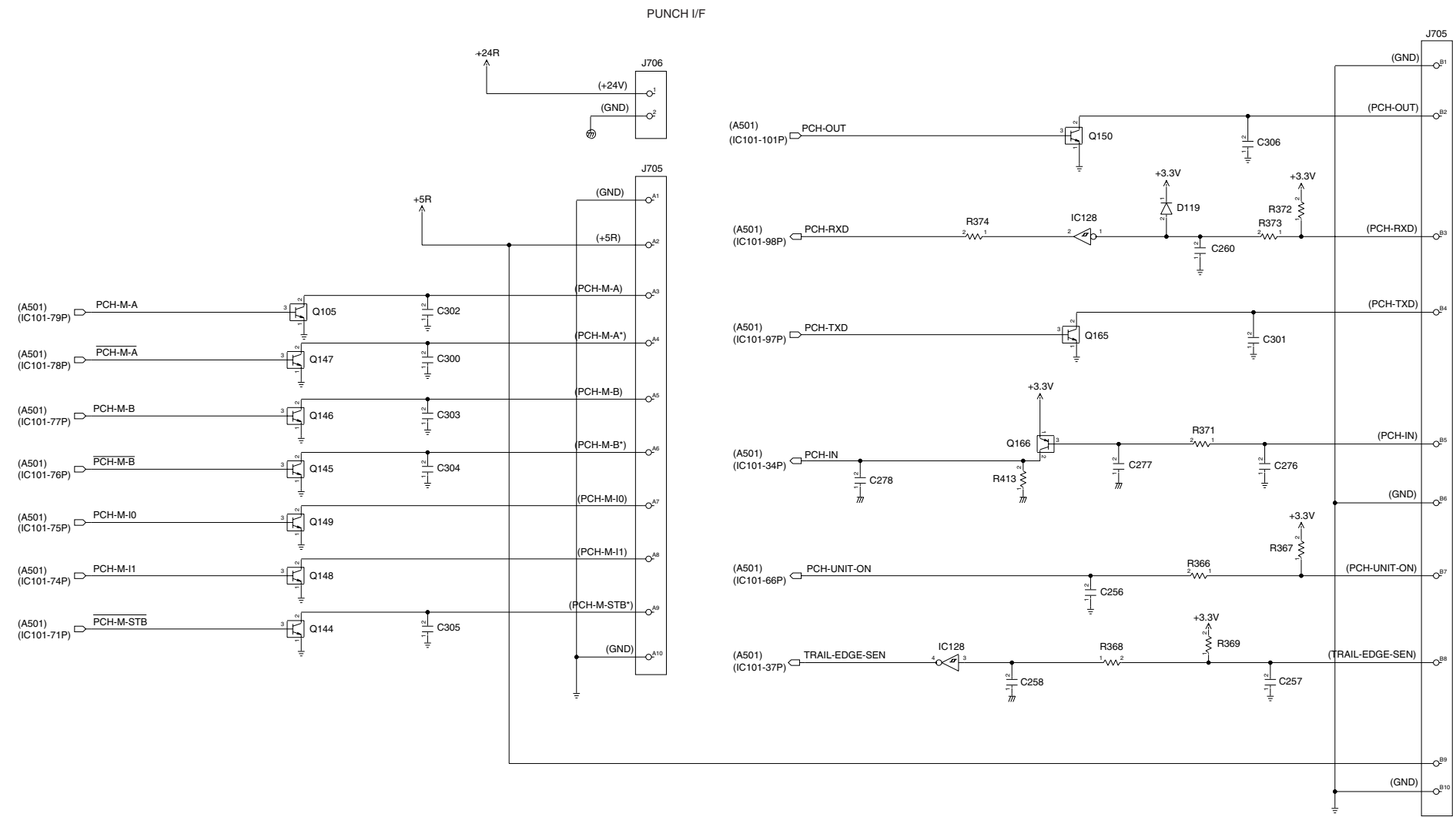

F-1-13

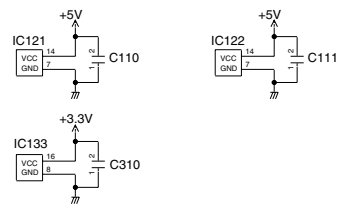
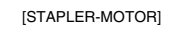
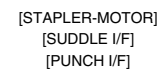
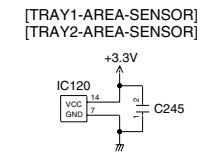
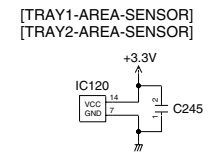
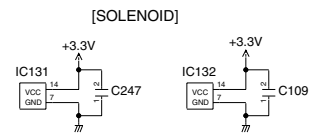

F-1-14

2 Stapler PCB 1  
Stapler PCB1

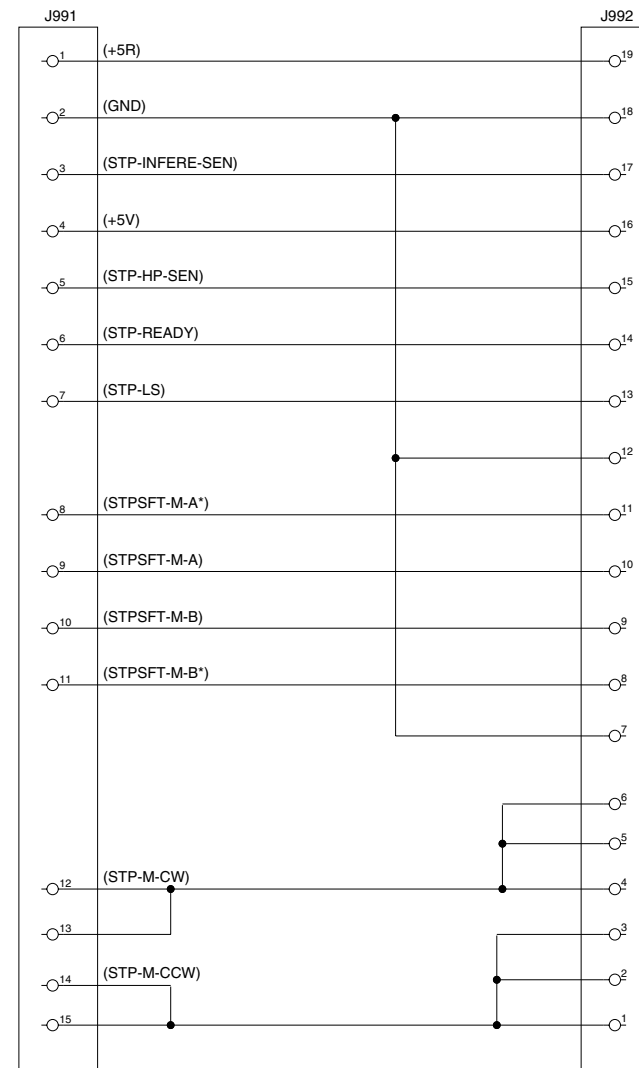

F-2-1



3 Stapler PCB 2  
 Stapler PCB2

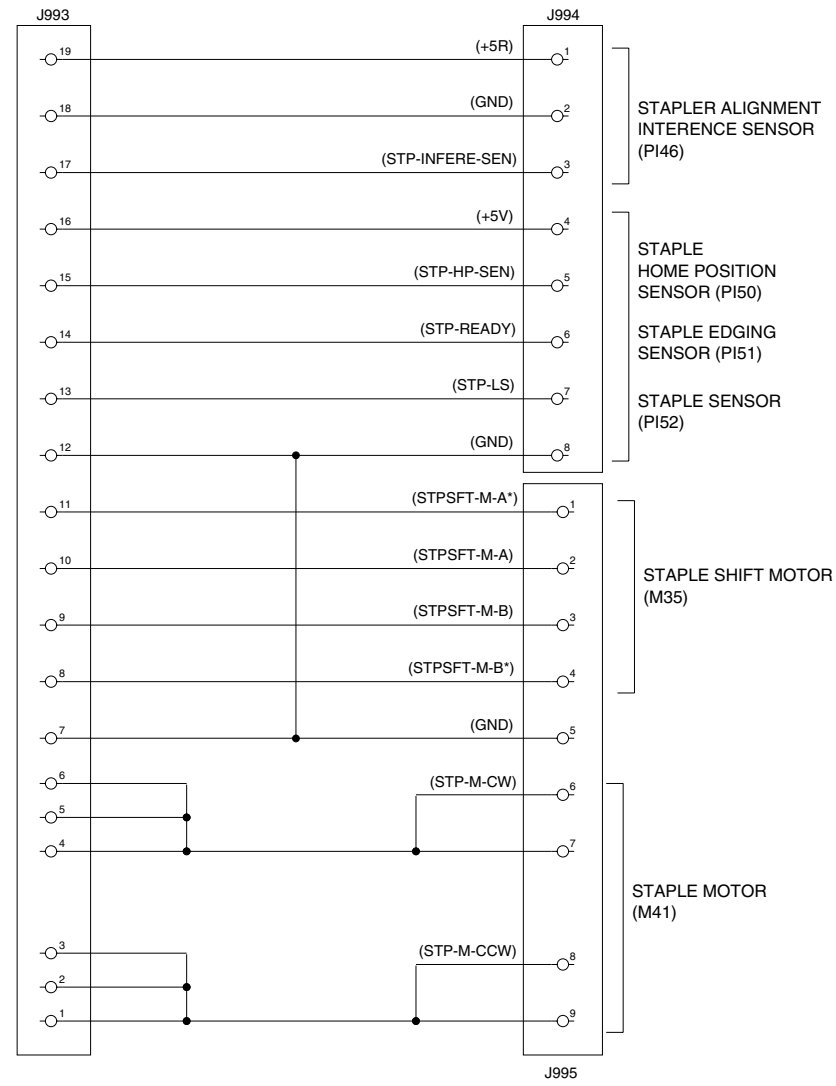

F-3-1





4 Tray2 Shift Area Sensor PCB  
Tray1/Tray2 Shift Area Sensor PCB

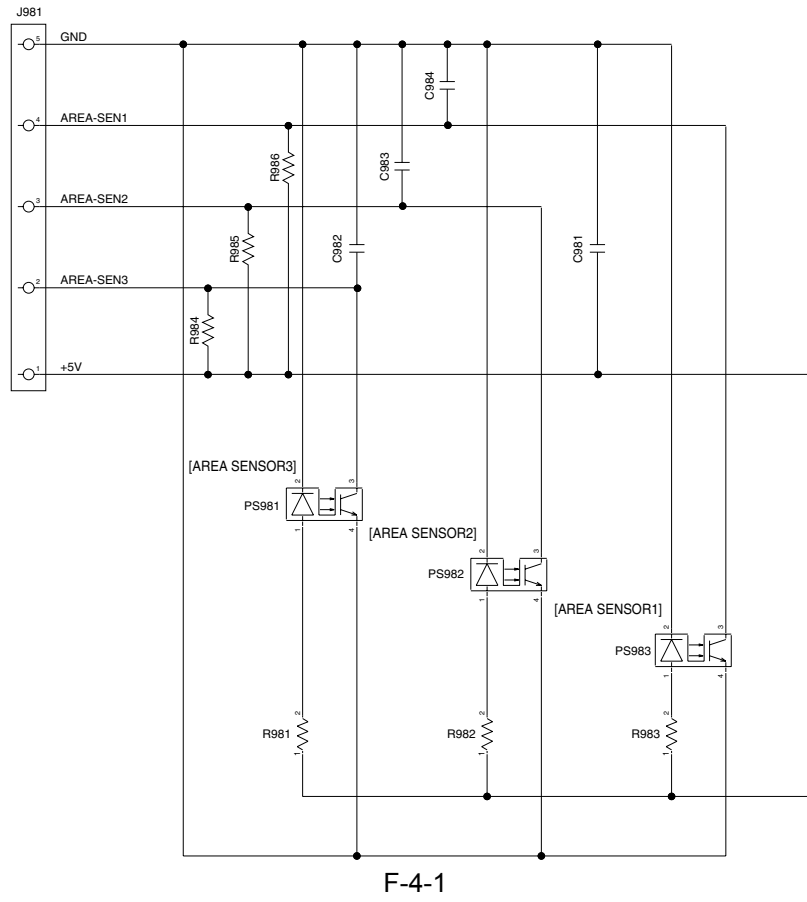



5 Tray1/Tray2 Driver PCB  
Tray1/Tray2 Driver PCB

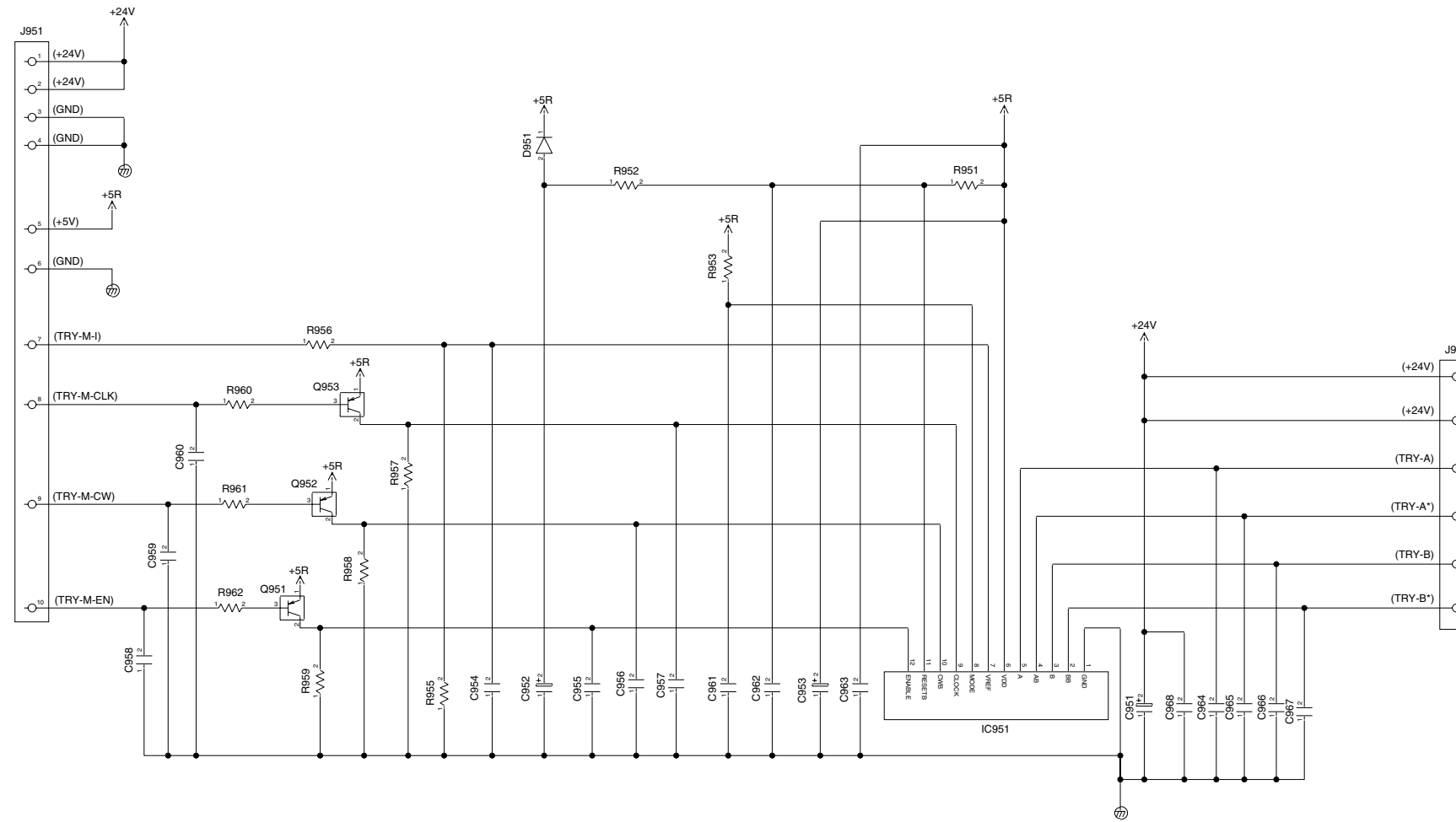

F-5-1



Nov 12 2003

**Canon**



